

**Contactor-based
automatic transfer switches**

Open transition
Closed transition

Delayed transition
Bypass isolation 40–1200A

**Experience,
innovation
and reliability**



EATON

Powering Business Worldwide



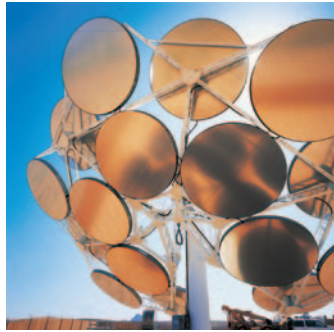

Built with years of experience

Powered with innovation

Delivered with reliability

A history of experience, innovation and reliability

As a premier industrial manufacturer, Eaton's electrical business is one of the world's leading suppliers of electrical control products and power distribution equipment with yearly sales of over \$2.5 billion. Eaton's electrical products include a complete line of low and medium voltage assemblies from substations, switchgear and panelboards to loadcenters, transformers and safety switches. These products are used wherever there is a demand for electrical power in residences, high-rise apartment and office buildings, commercial sites, hospitals and factories.

Built with experience

For over a century, Eaton has focused on providing quality power-centric products and services. In today's business environment, customers like you are driving our transformation from a leading global electrical components provider into a customer-centric solutions partner who understands your business. We do this through in-depth collaboration with customers and subject matter experts studying the issues inherent to the electrical power distribution and control systems.

Eaton is one of the pioneering electrical manufacturers and has been focused on providing reliable backup power systems with transfer switch equipment for over 75 years.

Powered with innovation

Eaton continues to meet changing industry needs by providing a broad range of automatic transfer switches. These switches may be grouped into a basic, enhanced or premium set of features that will meet your application requirements. Eaton has used industry-leading breaker-based designs for years and now has a line of contactor-based designs.

These designs can be matched to a family of automatic transfer switch controllers that will meet your specific needs. Identify your application, define your needs, and select the solution from Eaton.

Delivered with reliability

Power outages due to bad weather or utility failure have grown increasingly costly and more disruptive to businesses and homeowners. A backup power system will keep your computers, security system, heating or refrigeration system, cash registers, home health care equipment, or any system that uses electric power energized and operational. The demands for reliability have increased. Eaton meets those expectations by the stringent UL® 1008 automatic transfer switches with a world-class product delivery system.

Eaton will provide the individual transfer switch built to exacting standards or supply the same transfer switch in an integrated lineup with other Eaton gear. For startup service, application support and emergency support, call Eaton Electrical Services & Systems at 1-800-498-2678.



Contactor-based transfer switches

Switch type—overview and standards



Solutions overview

Eaton's automatic transfer switches are designed to provide you with a full offering of transfer switches to solve your industry and application needs. Eaton offers the industry's most complete line of contactor-based, breaker-based, and Magnum™-based transfer switches.

This wide range of selections enables you to identify your application needs and the benefits you expect to realize, and then choose the solution best for you. The cornerstone of these offerings is the proven design experience and reliability built into all Eaton transfer switches.

Basic solution

The basic solution offers a transfer switch that meets the most basic and cost-effective requirements for an automatic, manual or non-automatic transfer switch.

This solution set allows you to choose from either a contactor-based or a breaker-based design and match that power-switching device with our basic transfer switch controller.

Enhanced solution

The enhanced solution meets all of the basic automatic transfer switch needs. In addition to meeting the most basic transfer switch requirement, the enhanced solution allows for optimal control and improved flexibility. This solution set allows you to choose from either a contactor-based or a breaker-based design.

Premium solution

The premium solution is offered for those applications requiring continuity of power during the transfer and routine test. This solution set offers both contactor-based and breaker-based designs with drawout capability.

Switch types available

- Open transition
- Closed transition
- Delayed transition
- Bypass isolation

Transfer Switch Standards

UL 991	UL standards for safety tests for safety-related controls employing solid-state devices
UL 1008	Dielectric test
NEMA® ICS 109.21	Impulse withstand test
IEEE® 472 (ANSI C37.90A)	Ring wave immunity/voltage surge test
EN55022	(CISPR11): Conducted and radiated emissions
EN61000-4-2 Class B	Level 4 ESD immunity test
EN61000-4-3	(ENV50140) Radiated RF, electromagnetic field immunity test
EN61000-4-4	Electrical fast transient/burst immunity test
EN61000-4-5	IEEE C62.41: Surge immunity test
EN61000-4-6	(ENV50141) Conducted immunity test
EN61000-4-11	Voltage dips and interruption immunity
FCC Part 15	Conducted/radiated emissions (Class A)
CISPR 11	Conducted/radiated emissions (Class A)
IEC 1000-2	Electrostatic discharge test
IEC 1000-3	Radiated susceptibility tests
IEC 1000-4	Fast transient tests
IEC 1000-5	Surge withstand tests
CSA® conformance	C22.2 No. 178-1978 (reaffirmed 1992)
UL 869A	Reference standard for service equipment
UL 50/508	Enclosures
NEMA ICS 1	General standards for industrial control systems
NEMA ICS 2	Standards for industrial control devices, controllers and assemblies
NEMA ICS 6	Enclosures for industrial controls and systems
NEMA ICS 10-1993	AC automatic transfer switches
ANSI C33.76	Enclosures
NEC® 517, 700, 701 and 702	National Electrical Code®
NFPA® 70	National Electrical Code
NFPA 99	Health care facilities
NFPA 101	Life Safety Code®
NFPA 110	Emergency and standby power systems
EGSA 100S	Standard for transfer switches
CSA C22.2 No. 178-1978	Canadian Standards Association

Make the right decision:

- Identify your application
- Define your needs
- Determine your right solution
- Select Eaton

ATS Solution Guide: Highlighting Contactor-Based Designs ①



Eaton Solution	Customer Benefits	Key Features	Agriculture
Premium solution Continuity of power during retransfer Critical load transfer applications Maximum control and ultimate flexibility Maximum investment	Greater reliability to avoid lost revenue and production time Continuity of power through synchronization of sources Lower energy costs realized through managing demand charges No power interruption during switch inspection or testing	Soft load ramping 30 cycle, 85 kA short-time ratings Integral overcurrent protection available Drawout design	—
	Greater reliability to avoid lost revenue and production time Safe preventative maintenance without power interruption No power interruption during switch inspection or testing	30 cycle, 85 kA short-time ratings Integral overcurrent protection available Integrated service entrance solution Interchangeable bypass and switch devices Drawout design	—
	Greater reliability to avoid lost revenue and production time Safe preventative maintenance without power interruption No power interruption during switch inspection or testing	Interchangeable bypass and switch devices Drawout design standard Front access standard Dual ATS	—
	Greater reliability to avoid lost revenue and production time Lower energy costs realized from managing demand charges No power interruption during generator set testing	30 cycle, 85 kA short-time ratings Integral overcurrent protection available Integrated service entrance solution Drawout design available	—
	Greater reliability to avoid lost revenue and production time Lower energy costs realized from managing demand charges No power interruption during generator set testing	Paralleled in less than 100 ms Programmable field settings Communication capability	—
	Enhanced solution Momentary loss of power acceptable during retransfer Optimal control and improved flexibility Moderate investment	Ability to transfer large motor or inductive loads Allows loads to re-energize after transfer at normal inrush currents Avoid higher starting currents, which increase energy costs	30 cycle, 85 kA short-time ratings on power circuit breaker Integral overcurrent protection available Integrated service entrance solution
Ability to transfer large motor or inductive loads Allows loads to re-energize after transfer at normal inrush currents Avoid higher starting currents, which increase energy costs		Multi-tap transformer voltage selection available Easily adjustable time delays for the neutral position	—
Ability to transfer large motor or inductive loads Allows loads to re-energize after transfer at normal inrush currents Avoid higher starting currents, which increase energy costs		30 cycle, 85 kA short-time ratings on power circuit breaker Integral overcurrent protection available Integrated service entrance solution Drawout design available	—
Simplest of transfer switching solution Safe manual transfer under load		Equal withstand, interrupting and closing ratings Integral overcurrent protection available Integrated service entrance solution	Open transition Breaker-based (100–1000A)
Basic solution Momentary loss of power acceptable during retransfer Least critical load transfer applications Basic control and flexibility Minimum investment	Most simple operation Most cost-effective Application flexibility	Most compact offering Multi-tap transformer voltage selection available	Open transition Contactor-based (100–600A)
	Permits safe and convenient non-auto transfer under load	30 cycle, 85 kA short-time ratings on power circuit breaker Integral overcurrent protection available Drawout design available	—
	Permits safe and convenient manual transfer under load Most cost-effective manual transfer	Equal withstand, interrupting and closing ratings Integral overcurrent protection available Deadfront design	—
Special solution	Continuity of power for UPS applications	Required UPS bypass signal prevents unauthorized bypass High interrupting ratings Reliable, manually initiated electrical operation	—

① Emphasis in yellow bars.



Commercial	Industrial	Utilities	Institutions	Government	Communications	Data Center
—	—	Soft load Magnum-based (600–5000A)	Soft load Magnum-based (600–5000A)	Soft load Magnum-based (600–5000A)	Soft load Magnum-based (600–5000A)	Soft load Magnum-based (600–5000A)
Closed transition Bypass isolation Magnum-based (200–5000A)	Closed transition Bypass isolation Magnum-based (200–5000A)	Closed transition Bypass isolation Magnum-based (200–5000A)	Closed transition Bypass isolation Magnum-based (200–5000A)	Closed transition Bypass isolation Magnum-based (200–5000A)	Closed transition Bypass isolation Magnum-based (200–5000A)	Closed transition Bypass isolation Magnum-based (200–5000A)
Closed transition Bypass isolation Contactor-based (100–1200A)	Closed transition Bypass isolation Contactor-based (100–1200A)	Closed transition Bypass isolation Contactor-based (100–1200A)	Closed transition Bypass isolation Contactor-based (100–1200A)	Closed transition Bypass isolation Contactor-based (100–1200A)	Closed transition Bypass isolation Contactor-based (100–1200A)	Closed transition Bypass isolation Contactor-based (100–1200A)
Closed transition Magnum-based (200–5000A)	Closed transition Magnum-based (200–5000A)	Closed transition Magnum-based (200–5000A)	Closed transition Magnum-based (200–5000A)	Closed transition Magnum-based (200–5000A)	Closed transition Magnum-based (200–5000A)	Closed transition Magnum-based (200–5000A)
Closed transition Contactor-based (40–1200A)	Closed transition Contactor-based (40–1200A)	Closed transition Contactor-based (40–1200A)	Closed transition Contactor-based (40–1200A)	Closed transition Contactor-based (40–1200A)	Closed transition Contactor-based (40–1200A)	Closed transition Contactor-based (40–1200A)
Delayed transition Breaker-based (30–5000A)	Delayed transition Breaker-based (30–5000A)	Delayed transition Breaker-based (30–5000A)	Delayed transition Breaker-based (30–5000A)	Delayed transition Breaker-based (30–5000A)	—	—
Delayed transition Contactor-based (40–1200A)	Delayed transition Contactor-based (40–1200A)	Delayed transition Contactor-based (40–1200A)	Delayed transition Contactor-based (40–1200A)	Delayed transition Contactor-based (40–1200A)	—	—
Open transition Magnum-based (200–5000A)	Open transition Magnum-based (200–5000A)	Open transition Magnum-based (200–5000A)	Open transition Magnum-based (200–5000A)	Open transition Magnum-based (200–5000A)	—	—
Open transition Breaker-based (30–1000A)	Open transition Breaker-based (30–1000A)	Open transition Breaker-based (30–1000A)	Open transition Breaker-based (30–1000A)	Open transition Breaker-based (30–1000A)	—	—
Open transition Contactor-based (40–1200A)	Open transition Contactor-based (40–1200A)	Open transition Contactor-based (40–1200A)	Open transition Contactor-based (40–1200A)	Open transition Contactor-based (40–1200A)	—	—
Non-auto Magnum-based (200–5000A)	Non-auto Magnum-based (200–5000A)	—	—	—	—	—
Manual or non-auto Breaker-based (30–1000A)	Manual or non-auto Breaker-based (30–1000A)	—	—	—	—	—
Maintenance bypass Breaker-based (100–1000A)	Maintenance bypass Breaker-based (100–1000A)	Maintenance bypass Breaker-based (100–1000A)	Maintenance bypass Breaker-based (100–1000A)	Maintenance bypass Breaker-based (100–1000A)	Maintenance bypass Breaker-based (100–1000A)	Maintenance bypass Breaker-based (100–1000A)



Contactor-based transfer switches

Switch type—open transition



Contactor-Based ATS with ATC-300 Controller

Product description

The automatic open transition contactor-based transfer switch is the most basic design that will provide a fully functioning automatic transfer switch. An automatic open transition transfer switch may be used for those applications where emergency backup power is required but a momentary loss of power is acceptable on the retransfer from emergency to normal.

Features

Standard features

- Voltage and frequency sensing
- Multiple field-programmable or settable time delays
- Switch position indication
- Source availability indication
- Source 1 and 2 auxiliary contacts
- Mimic diagram
- Programmable plant exerciser
- System test pushbutton

Electrical ratings

- 40–1200A
- Up to 600V
- Two-, three- or four-pole
- NEMA 1, 3R
- 100% rated

Optional features

- Surge suppression options
- Spacer heater
- Metering options
- Stainless steel cover for controller

Commercial design highlights

- UL 1008 front access
- High withstand and closing ratings
- Compact design

UL 1008 Withstand and Close-on Ratings (kA)

UL 1008 Ampere Rating	480V		600V	
	Any Breaker	Specific Breaker	Any Breaker	Specific Breaker
100	10,000	30,000	10,000	22,000
200	10,000	30,000	10,000	22,000
260	35,000	50,000	35,000	42,000
320	35,000	50,000	35,000	42,000
400	35,000	50,000	35,000	42,000
600	50,000	65,000	50,000	65,000
800	50,000	65,000	50,000	65,000
1000	50,000	65,000	50,000	65,000
1200	50,000	65,000	50,000	65,000

Dimensions in Inches (mm)

Ampere Rating	Height	Width	Depth	Weight in lbs (kg)
40–100	38.68 (982.4)	18.31 (465.1)	13.34 (339.0)	156 (71)
150–200	38.68 (982.4)	18.31 (465.1)	13.34 (339.0)	164 (74)
225–400	48.74 (1238.0)	25.25 (641.4)	13.84 (339.0)	260 (118)
600–1200	79.35 (2015.5)	25.25 (641.4)	22.46 (570.5)	600 (272) ①

① Subtract 20 lbs. for two-pole and add 50 lbs. for four-pole.



Contactor-based transfer switches

Switch type—closed transition

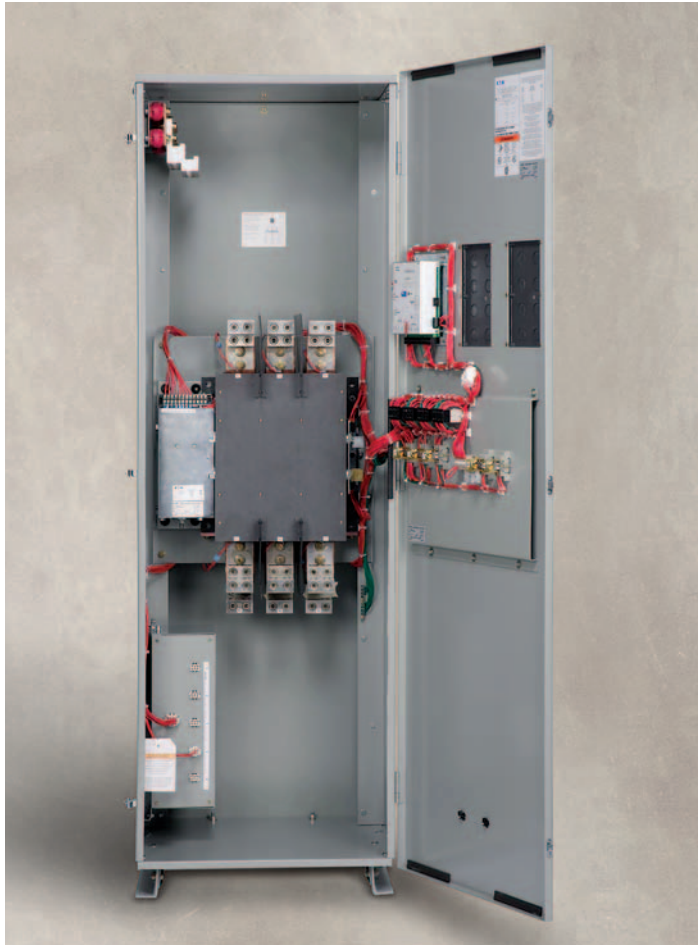

Closed Transition ATS with ATC-800 Controller

Product description

The automatic closed transition contactor-based transfer switch is the most basic design that will connect both sources before the transfer occurs. An automatic closed transition transfer switch may be used for those applications in which emergency backup power is required but a momentary loss of power is not acceptable on the retransfer from emergency to normal. Closed transition permits periodic testing of the emergency source without interrupting power to the loads.

Features

Standard features

- Voltage and frequency sensing
- Multiple field programmable time delays
- Switch position indication
- Source availability indication
- Source 1 and 2 auxiliary contacts
- Mimic diagram
- Programmable plant exerciser
- System test pushbutton
- Load shed from emergency

Electrical ratings

- 40–1200A
- Up to 600V
- Two-, three- or four-pole
- NEMA 1, 3R, 12
- 100% rated

Optional features

- Two- or four-position test switch
- Multi-meter options available
- Selectable automatic or non-automatic operation
- Space heaters
- Surge suppression
- Remote communications

Commercial design highlights

- UL 1008 three-position contactors
- High withstand and closing ratings
- Compact design

UL 1008 Withstand and Close-on Ratings (kA)

UL 1008 Ampere Rating	480V		600V	
	Any Breaker	Specific Breaker	Any Breaker	Specific Breaker
100	10,000	30,000	10,000	22,000
200	10,000	30,000	10,000	22,000
260	35,000	50,000	35,000	42,000
320	35,000	50,000	35,000	42,000
400	35,000	50,000	35,000	42,000
600	50,000	65,000	50,000	65,000
800	50,000	65,000	50,000	65,000
1000	50,000	65,000	50,000	65,000
1200	50,000	65,000	50,000	65,000

Dimensions in Inches (mm)

Ampere Rating	Height	Width	Depth	Weight in lbs (kg)
40–100	38.68 (982.4)	18.31 (465.1)	13.34 (339.0)	156 (71)
150–200	38.68 (982.4)	18.31 (465.1)	13.34 (339.0)	164 (74)
225–400	48.74 (1238.0)	25.25 (641.4)	13.84 (339.0)	260 (118)
600–1200	79.35 (2015.5)	25.25 (641.4)	22.46 (570.5)	600 (272) ①

① Subtract 20 lbs. for two-pole and add 50 lbs. for four-pole.



Contactor-based transfer switches

Switch type—delayed transition



Delayed Transition ATS with ATC-300 Controller

Product description

The automatic delayed transition contactor-based transfer switch is used in applications in which it is advantageous to have a time delay in the neutral position. This adjustable delay allows motor and transformer loads to decay, thus allowing normal inrush currents with the transfer.

Electrical ratings

- 40–1200A
- Up to 600V
- Two-, three- or four-pole
- NEMA 1, 3R
- 100% rated

Commercial design highlights

- UL 1008 three-position contactor
- High withstand and closing ratings
- Compact design

Features

Standard features

- Voltage and frequency sensing
- Multiple field programmable time delays
- Switch position indication
- Source availability indication
- Source 1 and 2 auxiliary contacts
- Mimic diagram
- Programmable plant exerciser
- System test pushbutton
- Load shed from emergency

Optional features

- Two- or four-position test switch
- Multi-meter options available
- Selectable automatic or non-automatic operation
- Space heaters
- Surge suppression

UL 1008 Withstand and Close-on Ratings (kA)

UL 1008 Ampere Rating	480V		600V	
	Any Breaker	Specific Breaker	Any Breaker	Specific Breaker
100	10,000	30,000	10,000	22,000
200	10,000	30,000	10,000	22,000
260	35,000	50,000	35,000	42,000
320	35,000	50,000	35,000	42,000
400	35,000	50,000	35,000	42,000
600	50,000	65,000	50,000	65,000
800	50,000	65,000	50,000	65,000
1000	50,000	65,000	50,000	65,000
1200	50,000	65,000	50,000	65,000

Dimensions in Inches (mm)

Ampere Rating	Height	Width	Depth	Weight in lbs (kg)
40–100	38.68 (982.4)	18.31 (465.1)	13.34 (339.0)	156 (71)
150–200	38.68 (982.4)	18.31 (465.1)	13.34 (339.0)	164 (74)
225–400	48.74 (1238.0)	25.25 (641.4)	13.84 (339.0)	260 (118)
600–1200	79.35 (2015.5)	25.25 (641.4)	22.46 (570.5)	600 (272) ①

① Subtract 20 lbs. for two-pole and add 50 lbs. for four-pole.



Contactor-based transfer switches

Switch type—bypass isolation



Bypass Isolation Switch with ATC-300 Controller

Product description

A bypass isolation transfer switch may be used to provide emergency power to life safety and other critical loads where maintenance of the main transfer switch, without interruption of power to the load, is either desirable or required.

- Installation flexibility
- Field entry/exit modification for top/bottom/both
- Interchangeable contactors

Features

- Reliable microprocessor logic
- Designed to safely withstand fault currents
- Eliminates need for complex interlocks
- Drawout cassette design
- No service interruption when bypassing to the same source
- Drawout capabilities on both ATS and bypass portions
- Ability to test power switching elements during drawout process
- Power switching devices completely interchangeable between ATS and bypass portions
- Capability to have a dual ATS—controller will work with the ATS and bypass contactor
- Open or closed transition

Electrical ratings

- 100–1200A
- Up to 600V
- Two-, three- or four-pole
- NEMA 1 and 3R enclosures
- 100% rated

Commercial design highlights

- UL 1008
- Easy access
 - Top/bottom entry
 - Isolated entry exit area
- Improved safety
 - Compartment barriers
 - Single-motion rack with door closed
 - Extended battery backup
 - Dual drawout ATS

UL 1008 Withstand and Close-on Ratings (kA)

UL 1008 Ampere Rating	480V		600V	
	Any Breaker	Specific Breaker	Any Breaker	Specific Breaker
100	10,000	30,000	10,000	22,000
200	10,000	30,000	10,000	22,000
260	35,000	50,000	35,000	42,000
320	35,000	50,000	35,000	42,000
400	35,000	50,000	35,000	42,000
600	50,000	65,000	①	①
800	50,000	65,000	①	①
1000	50,000	65,000	①	①
1200	50,000	65,000	①	①

① Consult Factory

Dimensions in Inches (mm)

Ampere Rating	Height	Width	Depth	Weight in lbs (kg)
40–200	90.00 (2286.0)	46.00 (1168.4)	32.00 (813.0)	1800 (817)
300–400	90.00 (2286.0)	46.00 (1168.4)	32.00 (813.0)	1800 (817)
500–600	90.00 (2286.0)	46.00 (1168.4)	32.00 (813.0)	1800 (817)
600–1200	90.00 (2286.0)	46.00 (1168.4)	32.00 (813.0)	1850 (840)

Contactor-based transfer switches Controller features



Contactor-Based Design ATS Showing Optional Controllers Available

Product description

The automatic transfer switch controller is a key component within the automatic transfer switch. It provides the intelligence to sense the proper conditions to initiate a transfer and a retransfer of the contactor. Eaton's automatic transfer switches come with the design flexibility of being applied with one of three controllers. All three controllers provide the basic functions needed to perform an automatic transfer.

ATC-100 controller

General description

The ATC-100 controller was designed as a multi-function microprocessor open transition controller with simplified customer settings. The front panel interface displays source availability and connection status as well as convenient engine start and test buttons. Controller parameters are set via jumpers on the printed circuit board.

Design highlights

- Mimic diagram with source available and connected LED indications
- Field selectable fixed time delays
- Permits system testing via a front screen pushbutton
- Complies with UL 1008 / CSA 22.2-178
- Generator test selectable—OFF, 7, 14, 28-day interval

ATC-300 controller

General description

From installation to programming to usage, the ATC-300 open transition controller was designed with operational simplicity in mind. The user-friendly front panel interface simplifies routine operation, programming, data presentation and setting adjustments. An LCD-based display provides the flexibility of a back-lit display for enhanced visibility.

Design highlights

- LCD-based display for programming, system diagnostic and help message display
- Mimic diagram with source available and connected LED indications
- Stores customer/factory established parameters in nonvolatile memory
- Field-programmable time delays
- Displays real-time and historical information with a time-stamped history log
- Permits system testing via a front screen test pushbutton
- Programmable plant exerciser—OFF, daily, 7, 14, 28-day interval programmable run times
- Complies with UL 1008 / CSA 22.2-178

ATC-800 Controller

General Description

The ATC-800 closed transition controller was designed with operational simplicity in mind. The user-friendly front panel interface simplifies routine operation, programming, data presentation and setting adjustments. An LCD-based display provides the flexibility of a back-lit display for enhanced visibility.

Design Highlights

- LCD-based display for programming, system diagnostic and help message display
- Mimic diagram with source available and connected LED indications
- Stores customer/factory established parameters in nonvolatile memory
- Field-programmable time delays
- Displays real-time and historical information with a time-stamped history log
- Permits system testing via a front screen test pushbutton
- Programmable plant exerciser—OFF, daily, 7, 14, 28-day interval selectable run times
- Communicate via Modbus communication protocol
- Complies with UL 1008 / CSA 22.2-178
- Load monitoring, delayed, in-phase and closed transition

Automatic Transfer Switch Controllers

Description	ATC-100	ATC-300	ATC-800
			
System Application Voltage	120/240V, 208V single-phase	Up to 600 Vac	Up to 600 Vac
Voltage Specifications			
Voltage measurements of:	Source 1 and 2	Source 1 and 2—VAB, VBC and VCA	Source 1, 2 and Load—VAB, VBC and VCA
Voltage measurement range	120–480 Vac	0–790 Vac rms	0–700 Vac rms
Operating Power	95–145 Vac	65–145 Vac	65–145 Vac
Frequency Specifications			
Frequency measurements of:	Source 2	Source 1 and 2	Source 1 and 2
Frequency measurement range	50–60 Hz	40–70 Hz	40–80 Hz
Environmental Specifications			
Operating temperature range	–20 to 70°C	–20 to 70°C	–20 to 70°C
Storage temperature range	–30 to 85°C	–30 to 85°C	–30 to 85°C
Operating Humidity (Non-Condensing)	0 to 95% relative humidity (non-condensing)	0 to 95% relative humidity (non-condensing)	0 to 90% relative humidity (non-condensing)
Operating Environment	Resistant to ammonia, methane, nitrogen, hydrogen and hydrocarbons	Resistant to ammonia, methane, nitrogen, hydrogen and hydrocarbons	Resistant to ammonia, methane, nitrogen, hydrogen and hydrocarbons
Front Panel Indication			
Mimic diagram with LED indication	Unit status. Source 1 and 2—available and connected (5 total)	Unit status. Source 1 and 2—available and connected (5 total)	Automatic, test and program mode. Source 1 and 2—available, connected and preferred. Load energized (10 total)
Main display	N/A	LCD-based display	LED display
Display language	N/A	English, French	English
Communications Capable	N/A	N/A	PONI/INCOM
Enclosure Compatibility	NEMA 1 and 3R	NEMA 1, 12 and 3R, UV resistant faceplate	NEMA 1, 12, 3R and 4X UV resistant faceplate
Programming Selections			
Time delay normal to emergency	Selectable 2 or 15 seconds	0–1800 seconds	0–1800 seconds
Time delay emergency to normal	5 minutes—fixed	0–1800 seconds	0–1800 seconds
Time delay engine cooldown	1 minute—fixed	0–1800 seconds	0–1800 seconds
Time delay engine start	3 seconds—fixed	0–120 seconds	0–120 seconds
Time delay neutral	N/A	0–120 seconds	0–120 seconds or based on load voltage decay of 2%–30% of nominal
Time delay Source 2 fail	N/A	0–6 seconds	0–6 seconds
Time delay voltage unbalance	N/A	10–30 seconds	N/A
Voltage unbalance three-phase	N/A	0 or 1 (1 = enabled)	—
Percent of unbalanced voltage dropout	N/A	5%–20% (DO) dropout -2% to 3% (PU)	N/A
Phase reversal three-phase	N/A	OFF, ABC, CBA	N/A
In-phase	N/A	0 or 1 (1 = Enabled)	N/A
Load sequencing	N/A	N/A	Up to 10 devices (via sub-network)
Pre-transfer signal	N/A	1–120 seconds (Form C contact)	0–120 seconds up to 10 devices (via sub-network)
Plant exerciser	Selectable day, OFF, 7, 14, 28-day interval, 15 minutes run time, no load	Selectable—OFF, daily or 7, 14, 28-day intervals, 0–600 minutes, load or no load	Selectable—disabled or 7 day interval, 0–600 minutes, load or no load
Preferred source selection	N/A	N/A	Source 1 or 2 or none
Commitment to transfer in TDNE	N/A	N/A	Enabled or disabled
Re-transfer mode	N/A	N/A	Automatic or manual
Auto daylight saving time adjustment	N/A	0 or 1 (1 = Enabled)	—
System selection	Utility/generator or dual utility	Utility/generator or dual utility	Utility/generator or dual utility or dual generator
Closed transition frequency difference	N/A	N/A	0.0–3.0 Hz
Closed transition voltage difference	N/A	N/A	1–5%

Note: Features are order-specific. Not all features are supplied as standard.



Contactor-based transfer switches

Ordering information and basic components

Contactor-Based Automatic Transfer Switch Catalog Numbering System

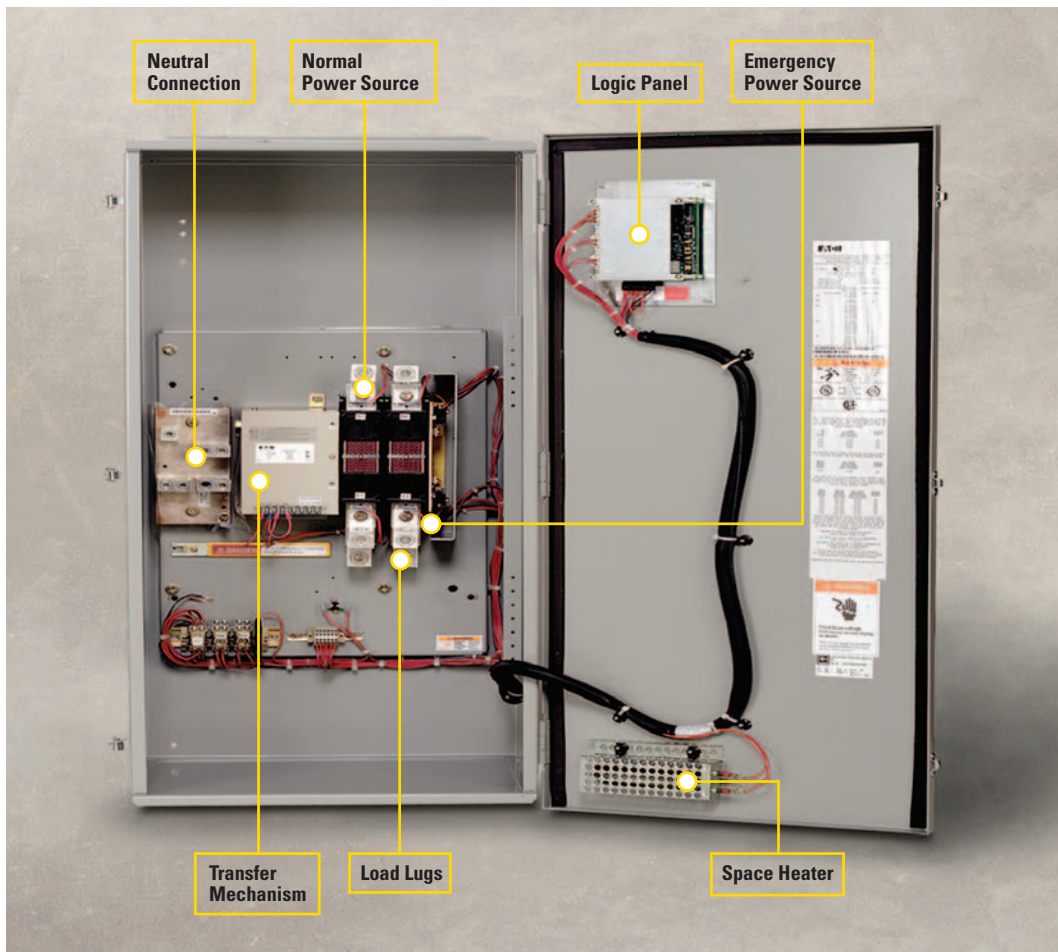
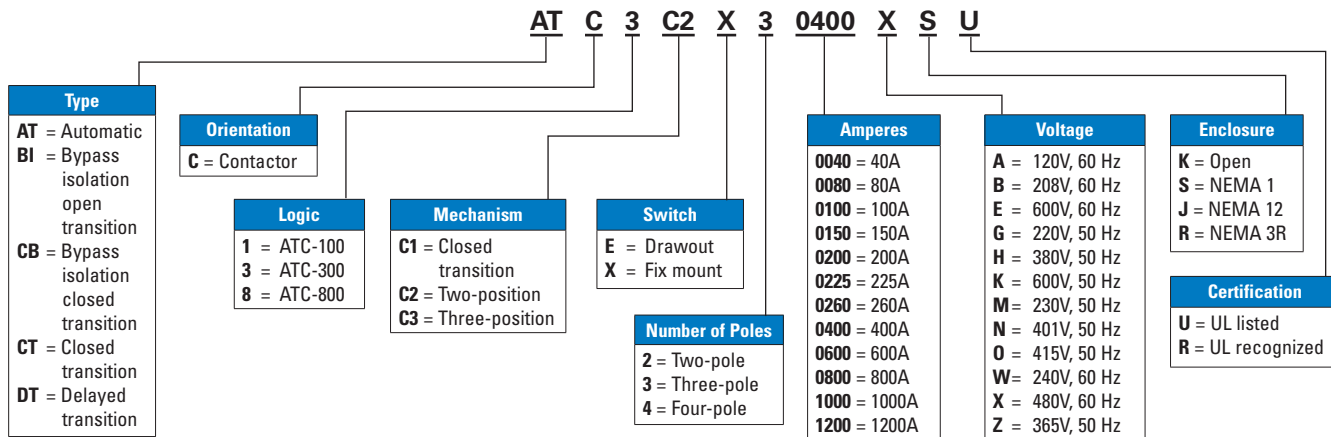

Automatic Transfer Controller (ATC-100)

- Monitors power sources
- Initiates transfer adjustable settings for time delays via jumpers
- Optional ATC-300 controller
- Space heater (optional)
- Transfer mechanism—two-position mechanism, motor operated

Typical Contactor-Based Design Components

Contactor-based transfer switches Integrated solutions



Integrated Solutions

Minimize initial equipment costs, reduce installation time, and increase system reliability. These are goals of all involved in placing electrical distribution equipment in service—from the design engineer to the electrical contractor, and especially the end user of the equipment.

Eaton believes that the transfer switch equipment is an integral part of the distribution equipment. This fundamental belief is why Eaton offers various types of transfer switches for the design engineer, electrical contractor and the user to choose from. Eaton offers contactor-based, molded-case and circuit breaker style switches.

All Eaton transfer switches are designed to meet the requirements set forth by UL 1008; however, all transfer switches are not created equal. You can be assured of safe and reliable operation from all types of transfer switches that Eaton offers.



Automatic Transfer Switch Integrated into a Switchboard Lineup



Satellite Facility Locations

Eaton's Electrical Sector is a global leader in power distribution, power quality, control and automation, and monitoring products. When combined with Eaton's full-scale engineering services, these products provide customer-driven PowerChain™ solutions to serve the power system needs of the data center, industrial, institutional, public sector, utility, commercial, residential, IT, mission critical, alternative energy and OEM markets worldwide.

PowerChain solutions help enterprises achieve sustainable and competitive advantages through proactive management of the power system as a strategic, integrated asset throughout its life cycle, resulting in enhanced safety, greater reliability and energy efficiency. For more information, visit www.eaton.com/electrical.

Eaton Corporation
Electrical Sector
1111 Superior Ave.
Cleveland, OH 44114
United States
877-ETN-CARE (877-386-2273)
Eaton.com

© 2010 Eaton Corporation
All Rights Reserved
Printed in USA
Publication No. BR01602001E / Z10438
November 2010



**PowerChain
Management®**

PowerChain Management is a registered trademark of Eaton Corporation.

All other trademarks are property of their respective owners.



Powering Business Worldwide